

Short Communication

Design and Construction of Photo Sensor Based Automatic Switch

*C. A. Quarcoo, B. K. Banini and B. E. Mensah

Abstract

Engineering Services Centre (ESC),
Ghana Atomic Energy Commission,
Legon, Accra.

*Corresponding Author's E-mail:
amaashong@yahoo.com

The aim of this project is to design and construct photo sensor based automatic switch. The switch operates by sensing a hand near the switch. The switching is without human intervention. Initiation is done by the user bringing the hand near the switch but not touching the switch to initiate the dispensing of liquid. The electronic components used for the design and construction are BP104, AN304, 10 K Ω resistors, 10 K Ω variable potentiometer, LM 741, IRF 3205 and LED. This seeks to prevent touching of control knobs to dispensed liquid. This switch uses 12V DC supply. It can be connected to 12V DC pump to dispense liquid such as oil, water and drinks. The switch was designed using photo sensors, general purpose operational amplifier, variable resistor and fast switching power MOSFET IRF3205. The output of this switch can be connected to a pump to dispensed liquid such as water, oil and drinks. The type of sensor used in this system is a photo sensor (an optical sensor). The sensitivity of the switch can be varied to suit indoor and outdoor application.

Keywords: MOSFET, LED, Semi-conductors, Sensor, Optical sensor, Sensitivity, Amplifier, variable potentiometers, linear photo sensitive diode

INTRODUCTION

The switch is designed to automatically switch on to dispense substance (for example liquid). The design implements a phototransmitter and photo receiver, general purpose operational amplifier, resistors, variable resistors, power MOSFET and light emitting diode. The input voltage is 12V Dc. This is enough to switch on a pump or any system that need to be automated. The output MOSFET is strong enough to switch on any system without additional relay. The switch connected to 12V DC output is strong enough for 12V DC motor applications.

MATERIALS AND METHOD

The Photo transmitter, photo receiver, resistors, variable resistor, a general purpose operational amplifier and a MOSFET were used to construct the circuit. The method used for the circuit construction was soldering. The components were placed on the electronic bread board and soldered using soldering iron and 40/60 solder for

electronic component. The LED is for operational status indication, in this case serving as an output indicator.

The electronic components used for the design and constructions are as follows:

1. BP104
2. AN304
3. 10 K Ω resistors
4. 10 K Ω variable potentiometer
5. LM 741
6. IRF 3205
7. LED
8. Battery
9. Target 3001 V30

The switch implements photo transmitter and photo receiver, IRF 3205 and LED in constructing the electronic circuit.

Resistors were used as current and voltage limiting components. Voltage dividers or potential divider, variable potentiometers or resistors were used to vary the voltage and current in the circuit (Kirchhoff's Law).

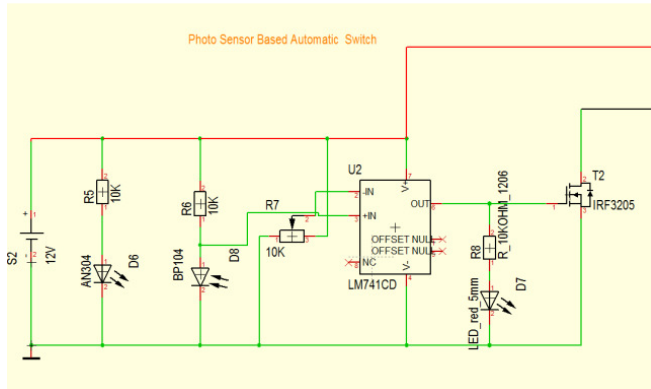

Figure 1. The switch circuit diagram

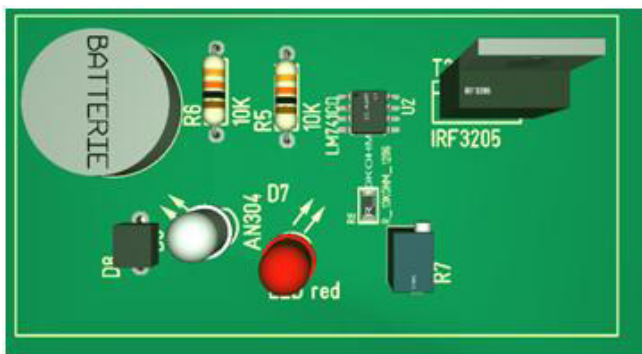

Figure 2. The switch 3D view top circuit diagram

Brief Theory

A photo sensor is an electronic component that detects the presence of visible light, infrared transmissions or ultra violet energy. Most photo sensors consist of semiconductor having a property called photo – conductivity, in which the electrical conductance varies depending on the intensity of radiation striking the material. Photo – sensor use a modulated light beam that is either broken or reflected by the target. The control consists of an emitter (light source), a receiver to detects the emitted light and associated electronics that evaluate and amplify the detected signal causing the photo – electric’s output switch to change its state. In a typical application, a photo – sensor placed in the entrance of a store to alert the presence of a customer. This is installed in such a way that when its beam is either broken or reflected by the customer, the photo – sensor will automatically switch on the motor responsible for opening the entrance door. Another application is in the use of automatic water faucets. This causes water to flow automatically through the tap when an object is placed under the tap and closes the tap when the object is removed.

Test detection range of a photo-sensor varies. The most important criterion to bear in mind when selecting a photo-sensor is its detection range and the associated

three-dimensional detection zone. In measuring the range, various standard reflectors are introduced into the detection zones from the side and the points at which these reflectors are detected by the sensor are marked. Objects may be introduced into the detection zone from any direction. Photoelectric sensors can check for presence, color, distance, size, shape, and many more targets attributes. They can perform these functions at longer distances than other sensing methods while providing numerous mounting options and flexibility. The maximum distance that this sensor can detect is defined "nominal range". Some sensors have adjustments of the nominal range or means to report a graduated detection distance. However, the detection range can be reduced due to a lot of factors such as, dirt accumulating on the surface of the sensor, misalignment of sensors, ageing etc.

The type of sensor used in the circuit diagram for the design and construction of the photo sensor based automatic switch circuit is BP104 and AN304. These are infrared sensors. There are numerous photo sensors that can be used examples are photo diode and photo transistor. Ultra sonic sensor can also be used.

The wavelength of the photo transistor is greater than the wavelength of the photo diode. The wavelength has to be considered to suit a particular application. Photo detectors can also be used.

RESULTS AND DISCUSSION

The switch was tested and the following are the results shown in table 1 and figure 3.

Table 1. Sensitivity and voltage

| Sensitivity (λ) in cm | | | | Voltage (V) in Volts | | | | $\frac{\lambda_2 + \lambda_4}{2}$ cm | V |
|------------------------|----|----|----|----------------------|----|----|----|--------------------------------------|-----|
| λ1 | λ2 | λ3 | λ4 | V1 | V2 | V3 | V4 | λ | V |
| 20 | 39 | 37 | 18 | 12 | 12 | 12 | 12 | 28.5 | 12 |
| 13 | 30 | 31 | 11 | 10 | 10 | 10 | 10 | 20.5 | 10 |
| 10 | 22 | 22 | 9 | 8 | 9 | 7 | 9 | 15.5 | 8.5 |
| 8 | 16 | 18 | 7 | 7 | 6 | 6 | 7 | 11.5 | 6.5 |
| 0 | 14 | 19 | 2 | 5 | 5 | 3 | 2 | 8.0 | 7 |

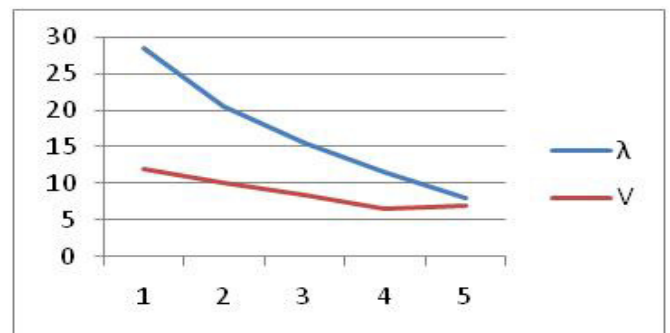

Figure 3. Sensitivity and voltage graph

DISCUSSION

The sensitivity (Λ) increases as the voltage increased and decreases as the voltage decreased. This is so because photosensor is sensitive to light and voltage. To avoid this interference a constant light or darkness must be created when implementing the photo sensor application. The photo sensor application can be used in a room or enclosed area. This is to prevent sunlight from interfering with the operational conditions. A variable port can also be used to set the sensitivity when the need arise. The sensitivity, Λ was calculated by using Λ_2 values and Λ_4 values. To calculate for Λ , the equation for the calculations is given by $\frac{\Lambda_2 + \Lambda_4}{2} cm$.

CONCLUSION

The photo sensor based automatic switch was designed and constructed as shown in figure 1 works to satisfaction. This is shown by the results provided in table 1 and the graph provided in figure 3. For design without BP104 that come with daylight blocking filters, the sensitivity of the switch is controlled using variable potentiometer. If the system is installed indoors the sensitivity control may be set once but if it installed outside the light and darkness will influence the sensitivity therefore sensitivity control variation would be necessary.

ACKNOWLEDGEMENT

The authors are thankful to the staff of Engineering Services Centre for their support during the design and construction of photo sensor based automatic switch.

REFERENCES

- Council for Technical and Vocational Education. Facilitating and Learning Materials Proficiency Level II Trade Area: Electronics. Unit 1 pg 18-21
- Electronics and circuit theory 7th edition. By Robert Boylestad Louis Nashelsky
- Electronics III. By DC Green fifth edition. Pg 198.
- Hughes Electrical Technology seventh edition. Pg 35.
- www.irf.com
- [www.Target 3001 V30](http://www.Target3001V30)
- www.ti.com